

RELAX

RT 25

Tweeter

- Hi fidelity 25 mm soft dôme tweeter
- Hi efficiency neodymium magnet
- HI quality special soft dome material
- Ferrofluid for hi power handling

TECHNICAL SPECIFICATIONS

Component	Tweeter	
Max power	100 W	
Nominal power	15 W	
Impedance	3,5 Ω	
Freq. Response	2,5 KHz -25 KHz	
Sensitivity (2,83V/1m)	90 dB	
Magnet	Neodymium	
Magnet size \varnothing x h	18 x 3 mm	0,709" x 0,118"
Total driver displacement	-	-
Weight of one component	0,096 kg	0,212 lb
Voice coil \varnothing	25 mm	0,984"
Voice coil height	2 mm	0,079"
Cone	Soft	

FREQUENCY RESPONSE / IMPEDANCE

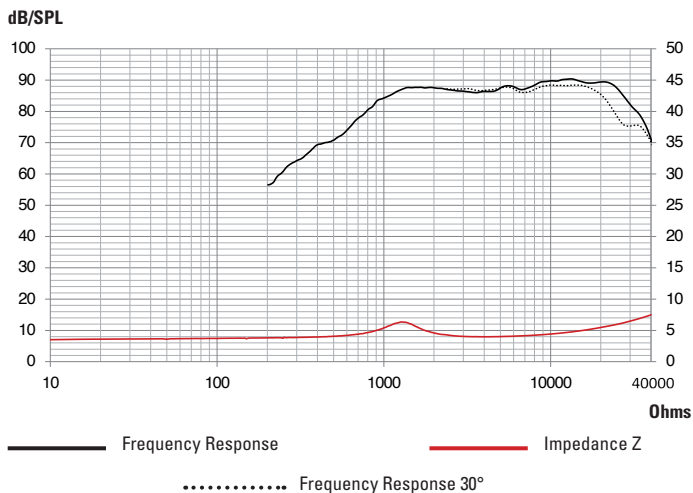

Guy Bonneville
BLAM
DRIVEN BY PASSION

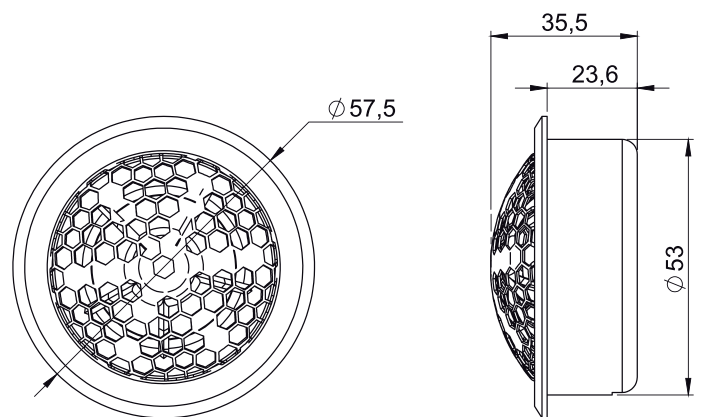

THIELE-SMALL PARAMETERS

effective \varnothing (d)	26 mm
Sd	5,31 cm ²
Xmax	-
Re	3 Ω
Fs	1322 Hz
Le	-
L2	-
Vas	-
Mms	-
Cms	-
BL	-
Qts	-
Qes	-
Qms	-
Sensitivity (dB/W/m)	86,4 dB

contact@blam-audio.fr
www.facebook.com/blamaudio
www.blam-audio.fr